

VALVE BATTERIES FOR COMMERCIAL FILTERS INSTRUCTION MANUAL

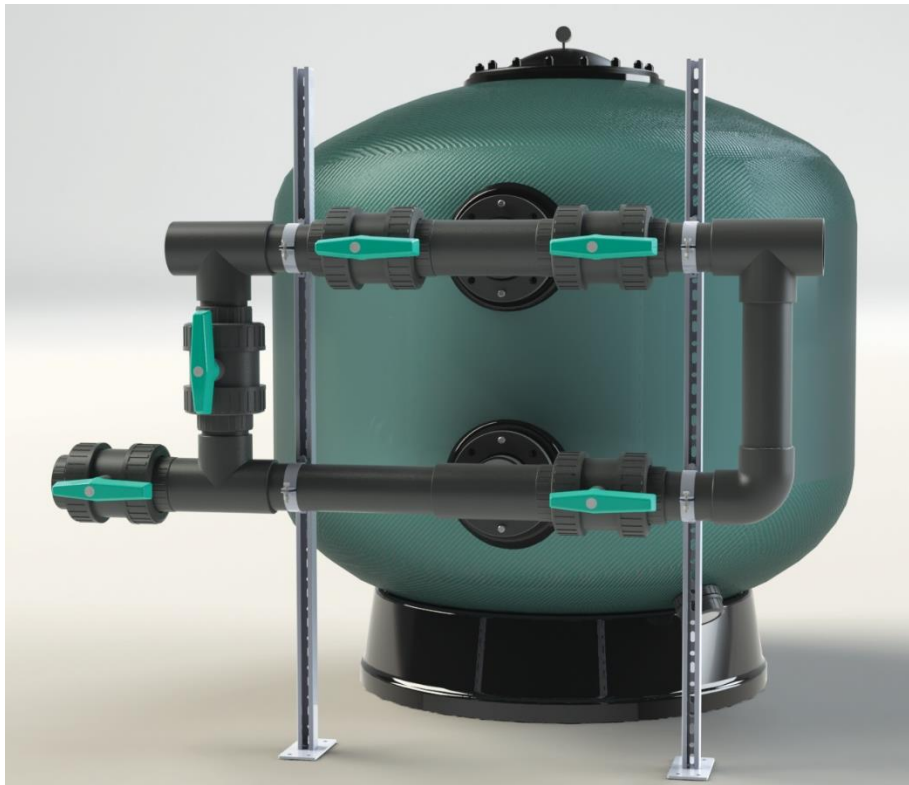

VALVE BATTERIES FOR COMMERCIAL FILTERS

1- GENERAL INFORMATION

1.1 Instruction

This manual provides the necessary instructions to install, use and maintain valve batteries. In order to obtain the benefits that are indicated in the characteristics, all the instructions that appear in this manual must be followed. This will offer a safe and long-lasting installation.

The equipment's supplier will provide further information to the user whenever it is needed.

2- DESCRIPTION

2.1 Description

These filters have been designed to provide water in pools and aquatic parks, also for all water treatments that require the elimination of suspended matter using the proper reduction of filtration element.

Apart from the filter itself, filtration and purification process include some points that must be taken into consideration as they can influence the correct filter operation. These would be chemical water treatment, pump equipment, pipe segments and general hydraulic design.

When public pools are concerned, the current rules in each country should be observed, as the installation must follow them.

The filtration quality depends on different parameters as depth of filtration bed, characteristics, quality and grade of filtration media, etc., as well as filtration rate.

3. INSTALLATION

3.1 Filter Installation

Filters are delivered properly packed and ready in order to facilitate unloading and transport using forklift truck, crane etc. It is very important to make sure that the filters have not suffered bumps during transport.

To obtain a correct filter installation, the following stages must be observed:

-Install filters on their final location.

-Install correctly the valve battery(ies) in the filters.

-Install battery supports and regulate them correctly (height, etc.).

-Connect batteries with the delivery pipe of the pumps, returns pipes and drain.

-Check the inner parts of each filter (nozzles, collectors, top, diffusers).

-Fill the filters with water.

-Empty half the water and add the filtration element (gravel, sand and/or anthracite), etc.

NO	DESCRIPTION
1.1	Water inlet for filtration
1.2	Filtrated water outlet
2	Diffuser
3	Collector
4	Sand Drainage
5	Filter Lid
6	Air Purge
7	Manometer

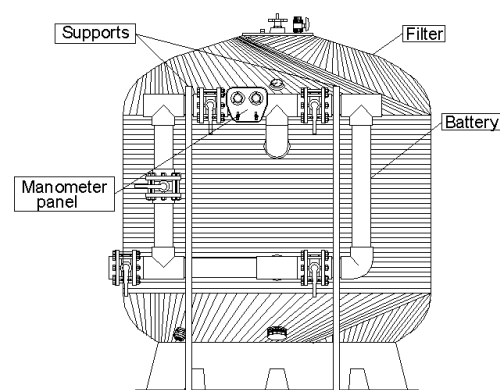

3.1.1 Filter location

Filters must be placed under the water level. However if vacuum occurs in the installation, suction cups must be installed in the lids to avoid that depression could collapse the filter's tanks.

Filters must be situated so that their bases are perfectly level and completely supported by the floor.

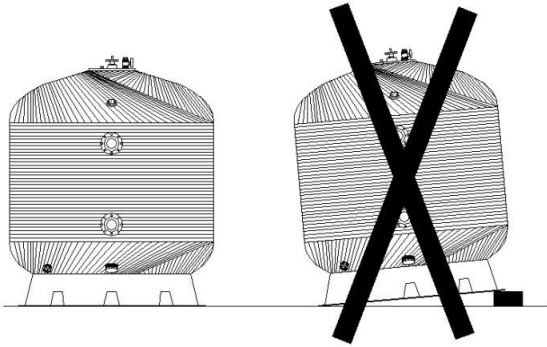

The location must have the appropriated size to allow maintenance periodic overhauls and any other work. Additionally the room must provide a drain to allow, in case of accident, evacuation of water flowing from any tube, filter, pump, etc. this will avoid risk of damages in the electrical installations (pump, electric panels, etc.)

3.2 Setting up the valve battery

Valves battery is delivered completely equipped, with four or five valves, (depending on your order), and its manometer panel with its corresponding connections. Filters connections may be flange polyester outlets of Ø200 up to Ø250 or with PVC outlets of Ø63 up to Ø160.



Check the filters if they are situated in the suitable distance from batteries and that they are lined-up.

You can start placing the battery avoiding forcing the flanges. Check also that outlets have not been damaged and that they are completely clean and empty.

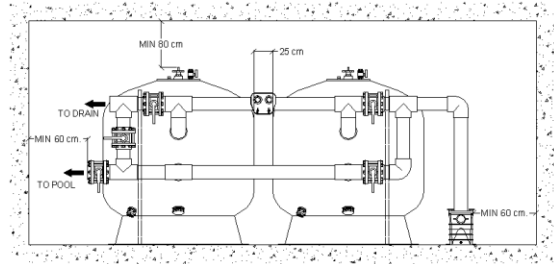
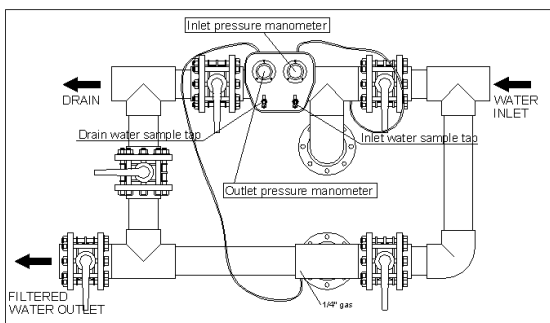

3.3 Battery installation



Once the battery is perfectly lined-up, it is necessary to install special supports to hold up the weight of the battery and the water that follows in it.

When the proper level and height have been achieved, the screw that supports the clamp must be tightened using a spanner.

In order to avoid that pulses and vibrations could damage or break the batteries when the tubes are being installed, other kind of supports are also available.

IMPORTANT NOTE:

Avoid the fixing system that blocks the normal dilation of materials.

If you have any doubt,

4. WORKING PROCESS

4.1 Filtration

It has to be done with the pump stopped and valves in position Fig 13.

During the filter functioning it is recommended to observe periodically the inlet and outlet manometers; the filtration element must be washed when the pressure difference between the two manometers is from 0.8 to 1 Kg/cm².

You can also install an automatic saturation alarm that will warn when the filter has achieved the selected pressure.

4.2 Backwash

The filtration bed forms thousands of channels that collect the impurities and solid waste contained in water.

In the course of time, sediment may block the collector system and dirt may blind the filter medium. In order to clean the filter, backwash must be carried out. Stop the pump and put valves in position, Fig 14.

The length of backwash will depend on the filtration element selected, but according to DIN 19643 the length should be 7 minutes, working on a rate of 50 m³/h/m² approximately.

It is advisable to put a sight glass in the overflow tube to check the length of backwash.

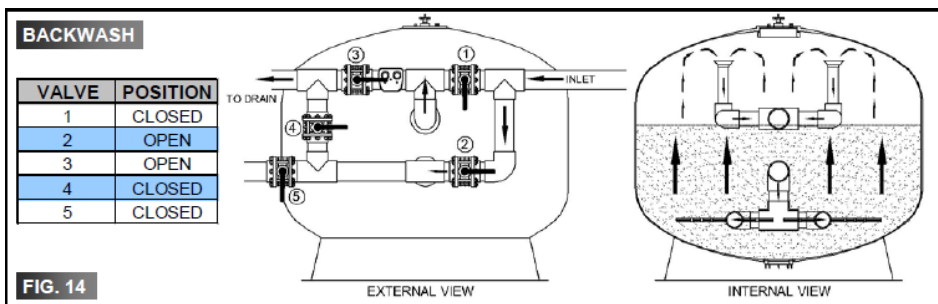
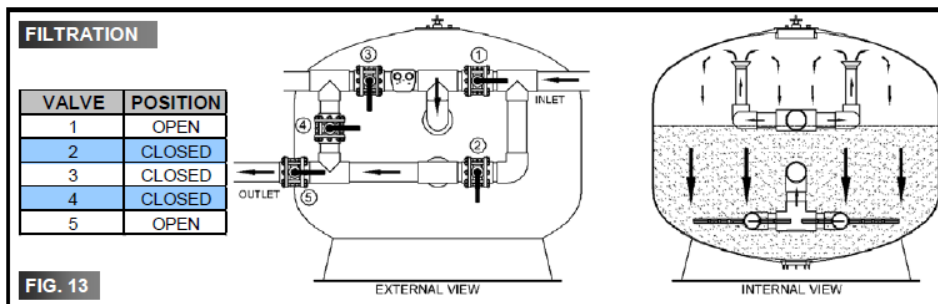

4.3 Rinse

This process can only be done when a five valve battery has been installed.

Rinse must be carried out immediately after backwash to discharge the remaining impurities that could have entered in the collectors during the filter's backwash. The length of rinse is 3 minutes (according to DIN 19643); this will prevent impurities appearing again in the network. To perform rinse, valves must be in position Fig. 15. Keeping the pump stopped; after this, they must be immediately returned to position of filtration.

4.4 Drain

When the pool has to be emptied, if its drain does not contain an overflow directly linked to the sewer, it can be drained using the filter's pump and putting valves in position. Fig. 16.

Before starting draining, it is necessary to check that the skimmer's valves, overflow channel and vacuum cleaners are closed.

5.5-Closed.

It is used to perform maintenance on the filter, clean prefilters, etc. As its name shows, all valves must be closed.

