



"Pool Technology"

HORIZONTAL FILTERS INSTALLATION MANUAL



BOBBIN WOUND SAND FILTERS FOR AQUATIC APPLICATION

IMPORTANT SAFETY INSTRUCTIONS
READ AND FOLLOW ALL INSTRUCTIONS
SAVE THESE INSTRUCTIONS

Declaration of Conformity

We declare, under our sole responsibility, that the product identified, and to which this declaration relates, are in conformity with the protection requirements of Council Directive 97/23/EC.



The manufacturer, Gemas has the right to modify the products without previous notice for as far as their characteristics are not really changed by this.

All rights reserved. This document is subject to change without notice.

Warranty conditions: 2 years limited warranty

IMPORTANT SAFETY INSTRUCTIONS

THESE OPERATING INSTRUCTIONS CONTAIN IMPORTANT INFORMATION ON THE SAFE, PROPER AND ECONOMICAL OPERATION OF THIS SWIMMING POOL APPLIANCE. STRICT OBSERVATION OF THE OPERATING INSTRUCTIONS WILL HELP TO AVOID DANGERS, REDUCE REPAIR COSTS, SHUTDOWN TIMES AND INCREASE THE RELIABILITY AND WORKING LIFE OF THE PRODUCT.

BOBBIN WOUND SAND FILTERS

1- GENERAL INFORMATION

1.1- INSTRUCTION

This manual provides the necessary instructions to install, use and maintain bobbin wound filters. In order to obtain the benefits that are indicated in the characteristics, all the instructions that appear in this manual must be followed. This will offer a safe and long-lasting installation.

The equipment's supplier will provide further information to the user whenever it is needed.

2- DESCRIPTION

2.1 Description

These filters have been designed to provide water in pools and aquatic parks, also for all water treatments that require the elimination of suspended matter using the proper reduction of filtration element.

Apart from the filter itself, filtration and purification process include some points that must be taken into consideration as they can influence the correct filter operation. These would be chemical water treatment, pump equipment, pipe segments and general hydraulic design.

When public pools are concerned, the current rules in each country should be observed, as the installation must follow them.

The filtration quality depends on different parameters as depth of filtration bed, characteristics, quality and grade of filtration media, etc., as well as filtration rate.

2.2 Filter's Characteristics.

The tank is made of resin of polyester and fiberglass, totally anticorrosive. Inside, it contains collectors and diffusers made of unalterable plastic material (PVC and ABS), tested against salt-water. They are supplied for a working pressure of 2.5 kg/cm², 4 kg/cm², or 6 kg/cm² and a maximum temperature of 50°C. Other specifications can be supplied upon request.

Filtration rates may be 20, 30, 40 and 50 m³/h/m², depending on the application and the kind of filtration elements that have been selected. Rate 50 is not recommended in public pools.

3. HANDLING & INSTALLATION

3.1 Handling

Filters must be lifted up with a strong steel cord through the eyebolts as shown in below diagram.

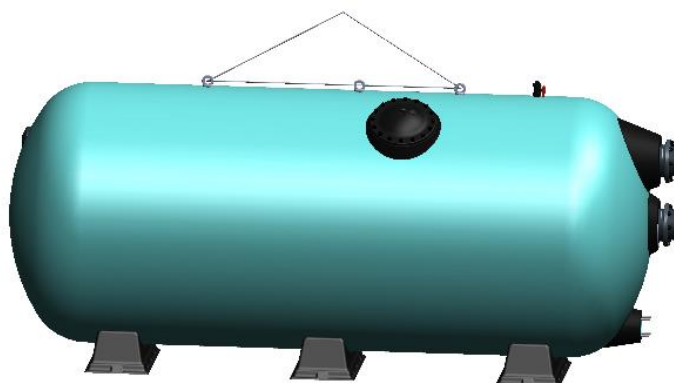

DO NOT LIFT UP FILTER FROM BOTTOM OF FILTER BODY AND DO NOT USE FORK LIFT. FILTER MUST BE LIFTED UP WITH CRANE FROM EYEBOLTS.

3.1.1-Filters location.

Filters must be placed under the water level. However if vacuum occurs in the installation, suction cups must be installed in the lids to avoid that depression could collapse the filter's tanks.

Filters must be situated so that their bases are perfectly level and completely supported by the floor.

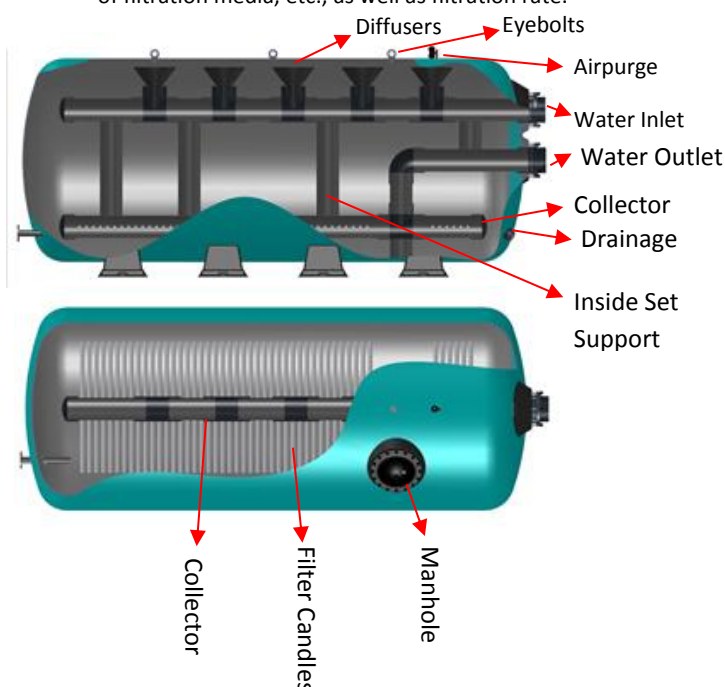

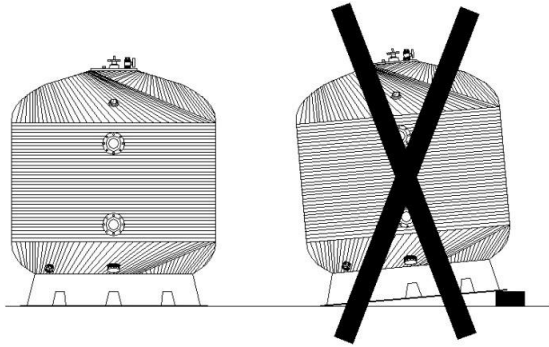

The location must have the proper space to allow maintenance periodic overhauls and any other work. Additionally the room must provide a drain to allow, in case of accident, evacuation of water flowing from any tube, filter, pump, etc. this will avoid risk of damages in the electrical installations (pump, electric panels, etc.)

3.2 Filter Installation

Filters are delivered properly packed and ready in order to facilitate unloading and transport using crane. It is very important to make sure that the filters have not suffered bumps during transport. Each package has a number label which corresponds with the pair of the stack set.

To obtain a correct filter installation, the following stages must be observed:

-Install bottom filter on their final location. Make Sure that the floor is leveled and all legs stand properly on the floor.



-Put upper filter onto bottom filter as shown on photo. Please carry the filters as instructed on 3.1 Handling of this manual.



DO NOT PUT UPPER FILTER ONTO BOTTOM FILTER IF BOTTOM FILTER IS NOT FILLED UP.

- Make Sure the holes of the legs correspond to each other as shown on below photo.



-Fix filters to each other with screws and nuts on every bases.

-Install correctly the valve battery(ies) in the filters.

-Install battery supports and regulate them correctly (height, etc.).

-Connect batteries with the delivery pipe of the pumps, returns pipes and drain.

-Before filling, Check that the inner parts of each filter (nozzles, collectors, top, diffusers) are in good condition

- First, fill minimum 1/3 of the bottom tank with water. Afterwards, fill the bottom tank with gravel (1-3 mm) and fine quartz sand. The filling must be made according to the "SAND LEVEL" levels on the filters

-After the filling of the bottom tank, apply the same filling sequence to the upper tank.

ALL GEMAS FILTERS ARE HYDRAULIC TESTED AT PRODUCTION FACILITY. NEVERTHELESS, IT IS ADVISED TO FILL THE TANKS WITH WATER AND TEST THE SYSTEM AT SITE, BEFORE FILLING WITH MEDIA. THIS IS A PRECAUTION TO OBSERVE ANY DAMAGES DUE TO HANDLING, TRANSPORT ETC.

ATTENTION!

ALWAYS FINALIZE THE FIXATION OF THE BATTERY AND PIPE SUPPORTS AFTER THE FILTER IS FILLED WITH WATER. OTHERWISE, WEIGHT OF THE FILLED WATER MAY CAUSE LEAKAGE.

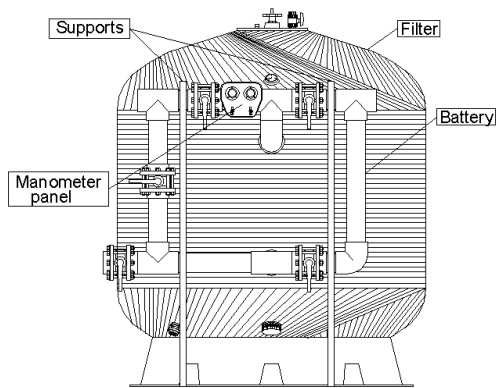

3.1.2 Setting up the valve battery.

Valves battery is delivered completely equipped, with four or five valves, (depending on your order), and its manometer panel with its corresponding connections. Filters connections may be flange polyester outlets of Ø200 up to Ø250 or with PVC outlets of Ø63 up to Ø160.



Check the filters if they are situated in the suitable distance from batteries and that they are lined-up.

You can start placing the battery avoiding forcing the flanges. Check also that outlets have not been damaged and that they are completely clean and empty.

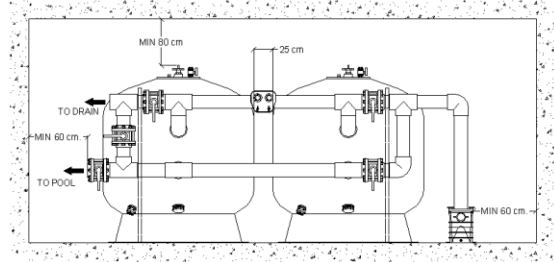
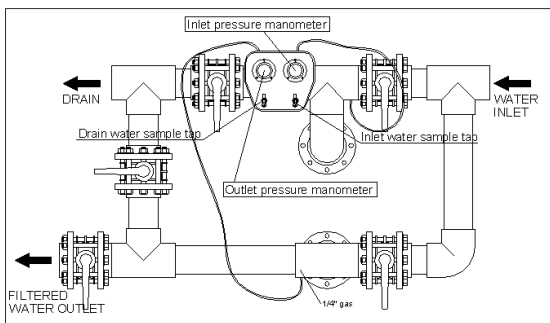

3.1.3 Manometers.

On pool filters, when the filter is clean, the usual pressures are:

-Inlet pressure: 0.8-1 Kg/cm²

-Outlet pressure: 0.4-0.6 Kg/cm²

When the differential pressure between the two manometers is 1 Kg/cm² or higher, backwash must be carried out.

NOTE: Once the manometers have been installed, you should cut the two little caps that are placed in the backside of the panel.

These caps have been put there to avoid the spilling of the manometer's glycerin.

3.1.4-Battery installation.



Once the battery is perfectly lined-up, it is necessary to install special supports to hold up the weight of the battery and the water that follows in it.

When the proper level and height have been achieved, the screw that supports the clamp must be tightened using a spanner.

In order to avoid that pulses and vibrations could damage or break the batteries when the tubes are being installed, other kind of supports are also available.

IMPORTANT NOTE:

Avoid the fixing system that blocks the normal dilation of materials.

If you have any doubt,

4- STARTING

Before filling filters sand or other filtration elements, it is advisable to check the internal collectors to make sure that they have not been damaged during transport or installation. Afterwards, fill the filters and the water installation and make an hydraulic test. Thus, you will make sure that there is no leak and that equipment works properly.

Then stop the pumps, open each filter's lid (the filter must not be emptied without opening the lid, as it could collapse) and empty half the water that each filters contains.



Then, start filling the filter with sand or other filtration elements, taking into account that first of all you must put gravel up to the collector arms (10 cm. approx).

This must be done very carefully in order to avoid any damage in the lower components of the filter. When the filter is being filled with sand, this must be carefully spread over the surface.

Once the filter is full with the filtration elements clean the lid and the inner part of the manhole. This will prevent any debris and particles of sand affecting the seal of the joint. Please follow the filling order of the bottom filter first, and top filter second for dual stack filters.



No	Description
1	Filter lid
2	Filter lid gasket
3	Air purge
4	Air purge o-ring
5	Screw cap
6	Inox Nut
7	Washer Inox

Put the seal in the lid; then introduce the lid in the manhole, screws must be positioned according to screw gaps on the lid to fix with nuts, leaving it leveled and centered.

Washers and nuts must be put on screws and tightened.

5-WORKING PROCESS

5.1-Filtration.

It has to be done with the pump stopped and valves in position Fig 13.

During the filter functioning it is recommended to observe periodically the inlet and outlet manometers; the filtration element must be washed when the pressure difference between the two manometers is from 0.8 to 1 Kg/cm².

You can also install an automatic saturation alarm that will warn when the filter has achieved the selected pressure.

5.2-Backwash.

The filtration bed forms thousands of channels that collect the impurities and solid waste contained in water.

In the course of time, sediment may block the collector system and dirt may blind the filter medium. In order to clean the filter, backwash must be carried out. Stop the pump and put valves in position, Fig 14.

The length of backwash will depend on the filtration element selected, but according to DIN 19643 the length should be 7 minutes, working on a rate of 50 m³/h/m² approximately.

It is advisable to put a sight glass in the overflow tube to check the length of backwash.

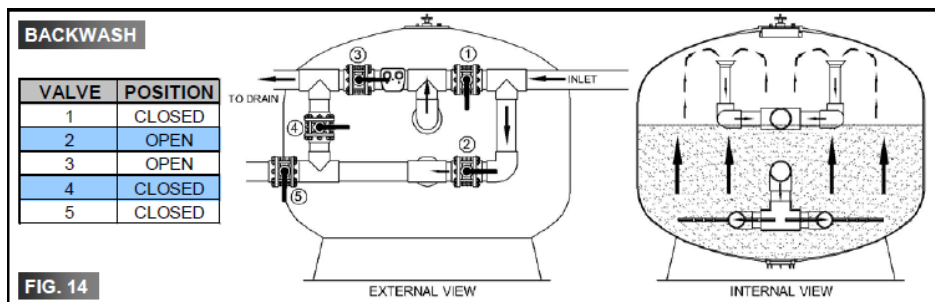
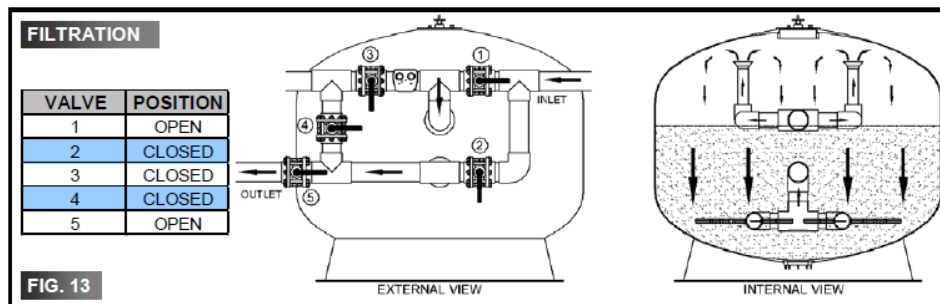

5.3 Rinse.

This process can only be done when a five valve battery has been installed.

Rinse must be carried out immediately after backwash to discharge the remaining impurities that could have entered in the collectors during the filter's backwash. The length of rinse is 3 minutes (according to DIN 19643); this will prevent impurities appearing again in the network. To perform rinse, valves must be in position Fig. 15. Keeping the pump stopped; after this, they must be immediately returned to position of filtration.

5.4-Drain.

When the pool has to be emptied, if its drain does not contain an overflow directly linked to the sewer, it can be drained using the filter's pump and putting valves in position. Fig. 16.

Before starting draining, it is necessary to check that the skimmer's valves, overflow channel and vacuum cleaners are closed.

5.5-Closed.

It is used to perform maintenance on the filter, clean prefilters, etc. As its name shows, all valves must be closed.

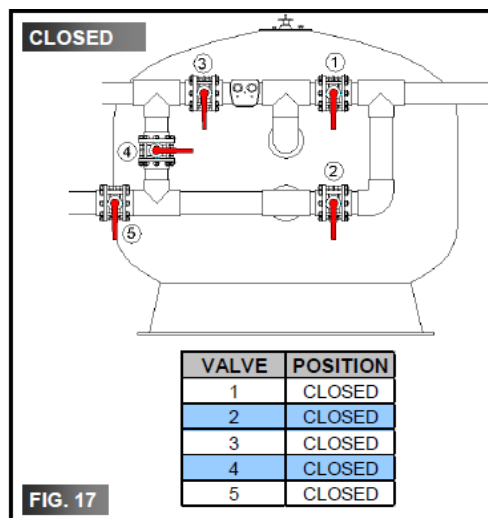
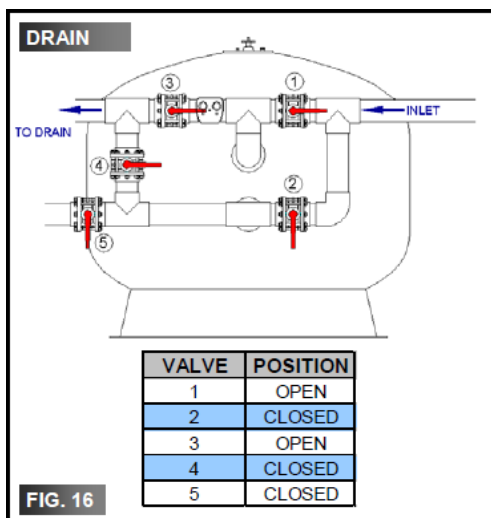
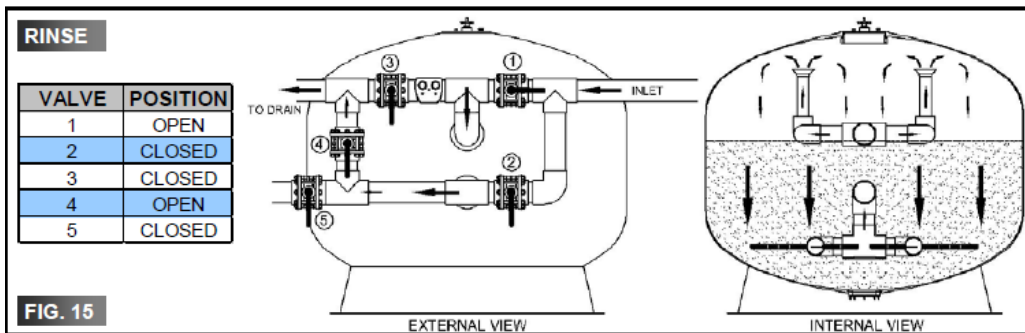

6- EMPTYING OF FILTERS SAND

To change sand or filtration media, proceed as follows:

1-Remove top lid.

2-Drain filter's water through the lower drainage hole.

3- Always Start Emptying yje filter from the TOP filters for Dual Stack Filters

4-If there is enough clear space, sand can be removed though the man hole. It can also be removed unscrewing the lower drainage hole.

4-To refill the filter with sand, follow the instructions given in starting, checking first of all that the drainage hole has been perfectly fitted and that it does not leak water.

7- OTHER RECOMMENDATIONS

-If the equipment has been stopped during a long period of time, it is recommended to empty the water filter.

-If the filter is situated outside, it is recommended to paint it with a suitable product every two years.

-In standard filters, ozone water treatments must not be used and pressure and temperature specifications not be exceeded. Contact our technical department if you have any doubt about the use of our filters.

-During the washing process, pressure must never exceed 1 Kg/cm² for filters with plate with nozzles.

-Optionally, high performance filters can also be delivered with lateral man hole and sight glass, as well as special inner finishes of high maintenance quality and chemical resistance.

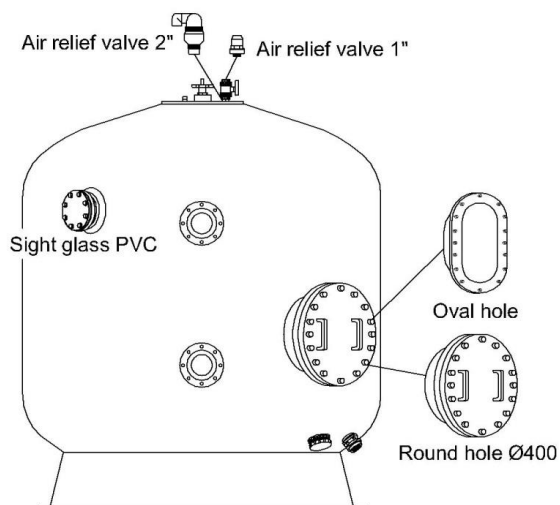

8- GUARANTEE

This filter has been manufactured using the best high technology materials and manufacturing process, going through strict quality test on materials, finishes and performance. All those bumps, rips and breakages caused by an inadequate use of the product or by ignoring our recommendations are not included in this guarantee.

The correct performance of the filter is guaranteed for 2 years.

This guarantee only covers the replacement or repair of defective spare parts in our factory. Extra charges like works made by third parties, compensations, etc... will not be accepted by the manufacturer.

BOBIN WOUND SAND FILTERS NOTES

