

GEMAS ANODE SHIELD

PREVENT ELECTROLYTIC CORROSION OF POOL METAL



Product Details: A zinc anode provides a shield that protects bathers from risk of electric shock, especially in fiberglass pools that lack metal bonding. Equally, when saltwater chlorinator disinfection systems are used, it prevents electrolytic corrosion of pool metal parts such as stainless steel ladders, heat pump heat exchangers, UV-C stainless steel casing, stainless steel lighting niches and face rings, aluminum pump motor housings, and salt chlorinator titanium cell plates.

Technical Characteristic

Main Features

1. Easy installation design by adding inline to existing 63 mm / 2" piping system
2. Excellent electric shock prevention in fiberglass pools
3. 4 Bar working pressure
4. Long life pure zinc alloy anode
5. 1 m 8 AWG solid copper wire and transparent lid for inspection

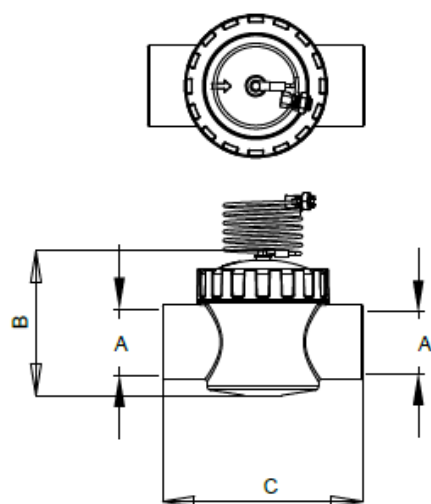

Code	Model	Raw Material	Connection	A (mm)	B (mm)	C (mm)
06423	GDF50-1E	ABS & PVC	63 mm	Ø 63	129	190
06425	GDF50-1A	ABS & PVC	2"	Ø 60	129	190

How It Works

1. Gemas Anode Shield is designed to prevent other metals from eroding. This inline zinc anode is already secured in a PVC TEE ready for installation.
2. Once installed, the Gemas anode will be consumed, instead of erosion/corrosion to other metal components surrounding the pool such as aluminum, stainless steel, cast iron, copper, and titanium.
3. The Gemas Anode Shield is tied into the pool bonding wire to protect the entire pool.
4. The anode should be replaced after half of it has been eroded, typically in about three years.



How to install

1. Cut pipe to size of the "TEE" shape shield
2. Glue "TEE" into pipe
3. Connect Copper wire to existing pump ground using split connector

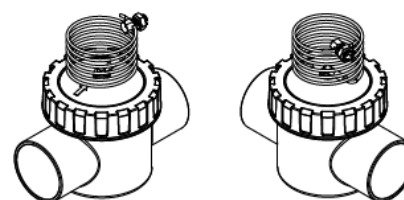

Typical installation and location

The best location for installation of the shield is in the water pipe after the filter and before a pool heater, that would put it before the salt cell. Without a heater, the shield should be put after the filter and before the cell.

